

# Development of an Intelligent Health Care Monitoring System

Gbemileke Iseoluwa Osinaike

Department of Information Technology, Federal University of Technology, Akure, Nigeria.

---

## **ABSTRACT**

The scarcity of medical personnel attending to a significant number of individuals seeking medical assistance is a pressing issue in healthcare institutions. Furthermore, there is a genuine concern regarding doctors' limited knowledge about their patients' lives beyond the boundaries of the hospital. This is a big problem, many of the emergency cases happen because doctors are disconnected from their patients after the hospital consultation. To overcome these challenges, this paper implemented an intelligent healthcare monitoring system leveraging IoT technology. By harnessing the capabilities of this IoT, healthcare professionals would be able to seamlessly perform their duties, while the system intelligently manages patient flow and prioritizes care. The integration of IoT technology in healthcare administration contributed to improved operational efficiency, resulting in the seamless delivery of medical services and optimized patient care. The results obtained from this research project demonstrated the effectiveness and efficiency of the proposed IoT solution, and highlighted its potential in addressing the identified problems in healthcare institutions.

## **KEYWORDS**

IoT, Diagnosis, Patients, Doctor, Vitals, APIs, Web Application, Analytics

---

Date of Submission: 01-07-2024

Date of acceptance: 12-07-2024

---

## **I. INTRODUCTION**

One of the concerns of health institutions especially in developing nations like Nigeria is how the few medical personnel can attend to the large number of people seeking medical help. What obtains presently is that one doctor attends to as much as 100 patients in a typical government hospital in densely populated areas. There is so much administrative delay making it impossible to give priority to critical medical cases.

Beyond this, is the concern that doctors know little about their patients outside the hospital confines. This is a big problem because many of the emergency cases happen because doctors are disconnected from their patients after the hospital consultation.

But they need to get real time on-the-spot information about their patients especially patients that need constant monitoring. Such monitoring is important because it helps to put the doctor on alert and also helps the patient get prompt attention and advice on what to do even when the doctor is far away.

A smart technology will readily solve these health concerns and issues. Such technology will help give information on critical cases so that the patient will get prompt attention.. It will also help check the excesses of some medical personnel in the hospital environment. There are reports that some patients are unduly delayed in the hospital even when they have critical cases because they don't know anybody that could help facilitate their cases.

Developing a smart system that monitors the health of a patient before it becomes a concern is important. It will aid in communicating in real time with the patient's family, physicians, nurses, and hospital staff in charge. Additionally, the system's identification, authorization, and secrecy features will assist avoid hospital delays.

A network of devices, networks, technologies, and human resources that cooperate to accomplish a single objective is known as the Internet of Things (IoT). There are numerous IoT-based applications that are used in various industries and have proven to provide significant benefits to users. This will come very handy in this project as we have to connect several devices for the reach of effective communication between different parties.

Many different aspects of human concern might be altered by the Internet of Things. Medical professionals can monitor patients both inside and outside of the hospital thanks to networked devices. The data gotten may then be analyzed by computers to assist practitioners change therapies and enhance patient outcomes.

The Internet of Things (IoT) is a network where many objects are connected and may communicate with one another across a computer network. (A. Whitmore et al, 2015). We may obtain information from sensors connected to this global network.

The development and enhancement of patient-doctor relations is the aim of IoT in the medical field. By aiding early symptom diagnosis, reducing the use of medical resources, and saving time for healthcare providers, such technology advancements improve patient outcomes. R.vani & D.subitha (2020).

The idea of the Internet is broadened and expanded by the Internet of Things. IoT makes it possible for many items, including household appliances, medical sensors, and security cameras, to communicate seamlessly with one another. (P.Gope and T.Hwang, 2015). IoT is consequently more efficient in a number of industries, including the healthcare industry.

The goal of the Internet of Things is to have self-reporting technology that can gather critical information in real time without human intervention, enhancing productivity.

Medical personnel will have a real-time information of their patients and also the system categorizes their conditions based on critical and non-critical cases enables the patient book an appointment with the doctor if it's a critical case.

By booking an appointment with the doctor who has a first-hand information about the patient helps prevent delay, as the patient comes to the hospital to see the doctor directly. Also, a smart system that assigns time to each patient as they have been appointed by the doctor will help prevent congestion and at the long run prevent delay in the hospital.

In this project, an intelligent monitoring system is proposed; It is based on cutting-edge technology such as the Internet of Things (IoT). The goal of the Internet of Things (IoT) is to have self-reporting technology that can gather critical information in real time without human intervention, enhancing productivity. This will help prevent congestion and at the long run prevent delay in the hospital. It will also help doctors to give appointment based on empirical evidence.

Medical personnel having a real-time information of their patients and also the system categorizing their conditions based on critical and non-critical cases enables the patient book an appointment with the doctor if it's a critical case. Booking an appointment with the doctor who already has a first-hand information about the patient helps prevent delay, as the patient comes to the hospital to see the doctor directly.

## **RELATED WORK**

Kashif et al. (2020) did a research on A Fuzzy Neural Network-Based Intelligent IoT-Based Healthcare System. The purpose of this study was to improve the store-and-forward architecture of traditional telemedicine, which has a number of limitations. These constraints include the need for a nearby health center with a dedicated staff, the requirement for Wi-Fi, the requirement for medical equipment to prepare patient reports, the 24-48-hour time limit for receiving diagnosis and medication information from a doctor in a large hospital, the price of nearby health centers, and the 24-48-hour time limit for receiving diagnosis and medication information from a doctor.

They saw how artificial intelligence has a profound impact on a number of industries, including the health sector. The objective of this research was to improve on the conventional telemedicine coupled with sensors, to improve diagnostic based on a fuzzy neural network method. The methodology was divided into three groups; Fuzzy Logic-Based Smart Healthcare Monitoring, Management and data collection which uses three sensors (body temperature sensor, pulse rate sensor, and heartbeat sensor) to collect data for smart healthcare. Even while fuzzy logic systems are good at explaining how decisions are made, the inference rules are a difficult assignment since they require prior knowledge.

The fuzzy logic is installed on the server, where it will direct choices on patient conditions and care while informing the physician of the patient's status. Oliver (2013). A set of fuzzy rules were created for the clinical decision support system used for IoT-based telemedicine. By using a decision support system, they were able to reduce the time constraints associated with the traditional store-and-forward approach of telemedicine in remote locations.

The system did not feature security measures to protect the information of patients on the network. It was only limited to android users to view the result

Gope and Hwang (2016) conducted a research on A Secure IoT-Based Modern Healthcare System Using Body Sensor Network. The idea that earlier BSNs (body sensor networks) had not effectively incorporated robust security features that may have secured patient privacy served as the inspiration for the study. This served as their inspiration for developing and promoting BSN-Care, a safe IoT-based healthcare system that effectively meets a number of security standards. BSN is the foundation of the healthcare system BSN-Care.

The primary aim of this project was to secure body sensor network-based Internet of Things healthcare systems' device authentication procedures. They presented a set of security criteria, a BSN-Care system, and enforced it in our BSN-Care model in order to achieve all of the essential security attributes. The study then proposes a secure IoT-based healthcare system that makes use of two authentication strategies and a BSN network architecture to address the aforementioned demands. This study focused on BSN-SYSTEM security (network security and data security).

At the end of the research, it was demonstrated that the proposed BSN-Care system could satisfy all the essential security requirements (Accomplishment of the Mutual Authentication, Anonymity, Secure Localization, Data Security) of IoT based healthcare system using BSN.

The new technology takes long time to implement and the cost of the system may be high. The research work majorly focused on security.

Kahkashan (2020) works on Internet of Things-Based Intelligent Health Monitoring. This research project's goals include developing a biomedical personal wireless network to monitor patient health in order to increase monitoring consistency and improve data quality and accuracy for decision support that will result in improved therapeutic treatments.

The methodology process was grouped into different parts (analysis, design model, analysis and visualization, experimental implementation, documentation, storage and backup, selection and preservation). In order to address different IoT and e-Health for future study throughout the world to ascertain how they may aid economies and society in terms of sustainable development, the research contributed to knowledge by leveraging the huge data collected. Finally, it was discovered that the computational intelligence approaches utilized would be used to evaluate, visualize, forecast, and ultimately identify answers to the unresolved problems in the healthcare system.

The limitation encountered in the research work was that there was no clear process in making inference from the data collected from the patients

Mariya et al. (2018) developed an IoT-based health monitoring system. In their research, they proposed a change in the way wireless sensors work by creating a system with various wireless sensors to collect data on the temperature, blood pressure, heart rate, and other aspects of the human body. This data will then be transmitted on an internet-accessible IoT platform.

This study suggests a health monitoring system that can measure many bodily characteristics, including blood pressure, temperature, and heart rate, and then communicate that information to an IoT server.

The methodology adopted in this project, they divided the system into hardware and software section. For the hardware section, they maximized hardware devices for health monitoring (temperature sensor, blood pressure sensor, Heartbeat Sensor, Communication network, Arduino). The purpose of the software part was to guarantee efficient bridging and improved system performance. By the end of the project, any abnormalities in a person's health conditions can be directly identified and communicated to that person via the internet. The temperature was measured using a precision integrated temperature sensor LM35, while the heartbeat was measured with the aid of a photodiode and a bright LED.

The proposed project was done and implemented but little or no attention was put into security of the patient's data.

Deep learning and artificial intelligence-based smart health monitoring were reviewed by Sujith et al. in 2022. Remote COVID patient condition monitoring is possible using SHM. Nowadays, everyone chooses tele-consultations and online appointments over hospital visits, medical shops, and public gathering programs where there is a higher likelihood of interpersonal communication because the COVID 19 epidemic has been mostly contained. S. S. Vedaei et al. (2020).

The goal of the research project is to discuss the newly developed technology, or SHM, its different parts, its subcategories, and the use of deep learning and artificial intelligence in managing the medical data produced by SHM. Data acquisition, communication gateways, and servers for effective data collection were employed in the assessment of medical IoTs as the necessary components for general architecture. Physical security, authentication, network security, computer security, and storage security are all parts of the data security that was embraced.

A review on "A Secure IoT-Based Modern Healthcare System Using Body Sensor Network" was done by Mubeen et al. (2018).

Due to a rising incidence of patient admission to hospitals, the health sector has been dealing with a number of hospital admission issues. This approach for human health care was proposed to achieve this goal. The goal of the proposed research project is to develop and put into use a system that can monitor any illness recommendation and offer patient health by utilizing fuzzy categorization technique. Utilizing wearable technology and an IoT framework, we collect patient data.

The system offers routine patient metabolic parameter monitoring together with illness identification based on parametric data. It is essential to offer ongoing health monitoring services at home due to the rise in unexpected mortality brought on by chronic heart failure or high blood pressure. The main objective was to create a dependable patient monitoring system that would enable medical personnel to keep an eye on patients who were either being treated in a hospital or going about their everyday lives as usual. Due to recently increased technology, patient monitoring systems are one of the biggest improvements. Patil et al. (2013)

In this research project, they combined the usage of an AES for data security with a fuzzy classification technique for prediction.

Training and testing were the two distinct processes that were separated for the proposed system. Data preparation, data cleaning, data gathering, outlier identification, and data conversion are all data mining techniques that can be used during training. The data is then utilized for testing, during which we connect all of the sensors to the Raspberry Pi and gather data from them using a batch processing technique. Using a connection-oriented design, all acquired data are stored in a single global database. Then, during the testing phase, we concurrently read all training and testing data. Apply a fuzzy classifier after that, then use a decision-making system to forecast potential outcomes. Provide the system's True Positive and False Negative results to complete the study.

The hardware and software components of the system's design are likewise separated into two categories. Temperature sensor, ECG sensor, heart-rate sensor, Raspberry Pi, GSM module, and Max 232 make up the hardware. The procedure was also described using a fuzzy classifier, an algorithm, and a mathematical model. The technology provides real-time health monitoring and online sickness prediction. It works with both fictitious and actual training data. Compared to other learning systems, prediction accuracy is greater. Additionally, the system has the ability to continuously send out notifications in the event of emergency.

This project's goals were all successfully met when it was launched. The suggested framework has several Java and also Mobile-based Android platforms communicated. The element significantly increases information loss for the ECG sensor (it could be useful for sensors with lower information rates), but pressure significantly increases the number of ECG devices that can be continuously used for a given packet loss rate.

The "IoT based Patient Health Monitoring System" research project was undertaken by Ms. Prachi et al (2021). Designing communication between the ambulance team and the monitoring station, or hospital, is the major goal. The project's goals were to offer a low-cost health monitoring system, a medical kit for ambulances, and a wealth of data to medical professionals. By splitting the Smart Ambulance Medi-kit into three parts—Sensor Modules, Microcontroller, and Wi-Fi Module—the technique employed in this project was the usage of some hardware components.

The limitation considered in this project was that only the doctors were considered as case study and no other medical personnel.

R.vani and D.Subitha's (2020) research looked at wearable health monitoring technology. The proposal was inspired by the existing method, which suggests a body-body communion system in place of wires and cables, posing a serious danger to the security and privacy of the data. This study intends to provide a body-to-body transmission application that avoids the drawbacks of high-tech technologies that require cables and wires for information transfer in order to advance the state of the art. They examined the current system and saw ways to make it better, so they proposed a new system that uses a novel strategy termed body-body communion. This method makes use of sensors to continually control important parameters including heart rate, breathing rate, humidity, dust levels, and ECG.

This method makes it easier for patients to control themselves, which reduces costs, medical resources, medical mistakes, waste production, and visits to healthcare professionals. Vani et al. (2017). They used some hardware components such as sensors, LCD, micro-controller, UART and Red Tactron. The limitation on this project is that based on the body-body communion the patients feel uncomfortable when worn for long and as such may be removed there-by leading to loss of transmission of information.

Azzawi et al. presented a review of the Internet of Things (IoT) in healthcare in 2016. This assertion states that IoT can unleash modern technologies and help to improve healthcare. Z. Bojkovic and D. Milovanovic (2017). The nature of Internet of Things (IoT) devices as a resource requires devices that need a unique authentication schema that doesn't use a lot of computation and energy resources.

Physical protection solutions and cryptography-based authentication solutions were the two primary categories of device identity security solutions that were recommended in this research. The technology that was employed was COAP with an authentication mechanism using the ECC algorithm. This study mainly concentrated on authentication mechanisms and downplayed the importance of IoT in healthcare.

Using IoT, Ghosh, A.M. et al. (2016) investigated remote health monitoring systems. A straightforward, low-cost health monitoring scheme is offered in this project after taking into account the enormous practical value of IoT-based live monitoring systems for patients at risk of heart attack, unequal accidents, and emergency cases. The project's objective was to provide a hospital management system for health monitoring that would allow patients' loved ones and consulting doctors to check on them online using an E-health sensor shield kit interface kit.

They worked on an E-health sensor shield kit interface kit as this guided them in achieving their aim. At the end of the research, though the deployment was successful, no email or SMS alerts or other notifications are sent to the appropriate family members or doctors.

After the review of these literatures, we saw improvements on existing technologies by different researchers. From the conventional ways of acquiring patient's information to exploring and exploiting IoT technologies therefore this has contributed to further areas for research on this project. There are different areas this literature has contributed to knowledge in different areas, however there are also limitations discovered in this research.

While some research work attempts to tackle security on patient’s data, on the other hand they fail to exploit IoT technologies in order to acquire real-time data and send the information to the appropriate desk. More so, some other research work focus more on the technology and methodology needed to acquire patient data, how to analyze the information for effective diagnosis but they fail to also secure the patient data.

This research project aims to apply the information gotten after the patient’s data has been acquired to solve administrative issues and also to help in better diagnosis, it aims to contribute to knowledge in the administrative sector of the health industry. This project also will leverage on previous research work done, maximize what has been done and also contribute to knowledge.

### SYSTEM ARCHITECTURE

This intelligent monitoring system is divided into three different sections that are interconnected with one another. With the use of the IoT (Internet of Things) technology, data may be transmitted over a network without the need for human-to-human or human-to-computer interaction. **IoT, analytics, and a web application** that serves as an interface for system users are the three distinct aspects of this project. By connecting to an IoT gateway or other edge device, which sends data to the cloud (database) for analysis, the IoT devices exchange the sensor data they gather.

The information stored on the cloud is therefore retrieved by the web-application in real-time which is first of all processed and analyzed to know how critical the patient’s vital is. This is where the second sections comes starts its work, this section does it analysis/diagnosis to know how serious the condition of the patient is before sending a notification to the doctor.

Then to the last phase of the application, the web-application. Here, the web application notifies the doctor and other medical personnel (the nurses) in the hospital based on the report obtained from the analytics phase so that an appointment with the doctor may be scheduled. And if an appointment is booked the patient receives a notification as to the time fixed by the doctor for appointment, in the long run to prevent delay of patients in the hospital.

The figure below, gives an overview of the architecture of the system. From acquiring the patient’s vitals to its processing, then to how the medical staffs utilize the information for other uses.

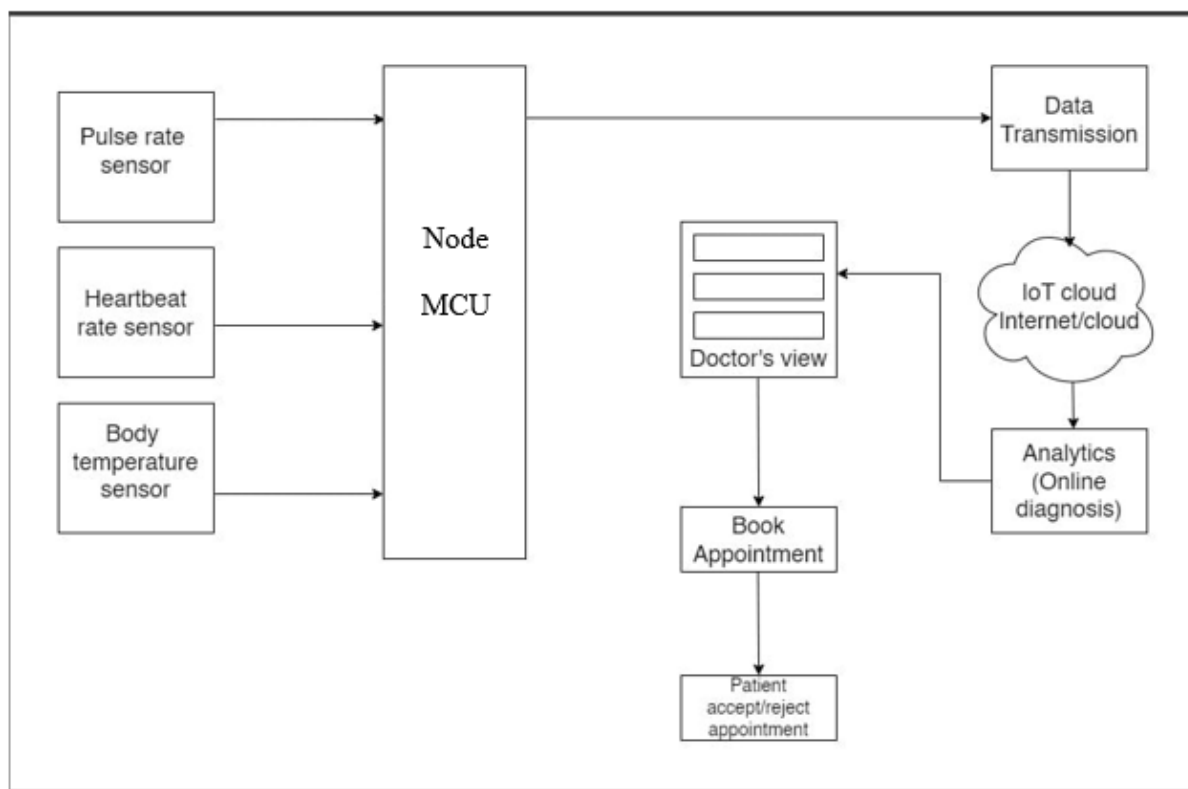



OVERVIEW OF THE SYSTEM'S ARCHITECTURE

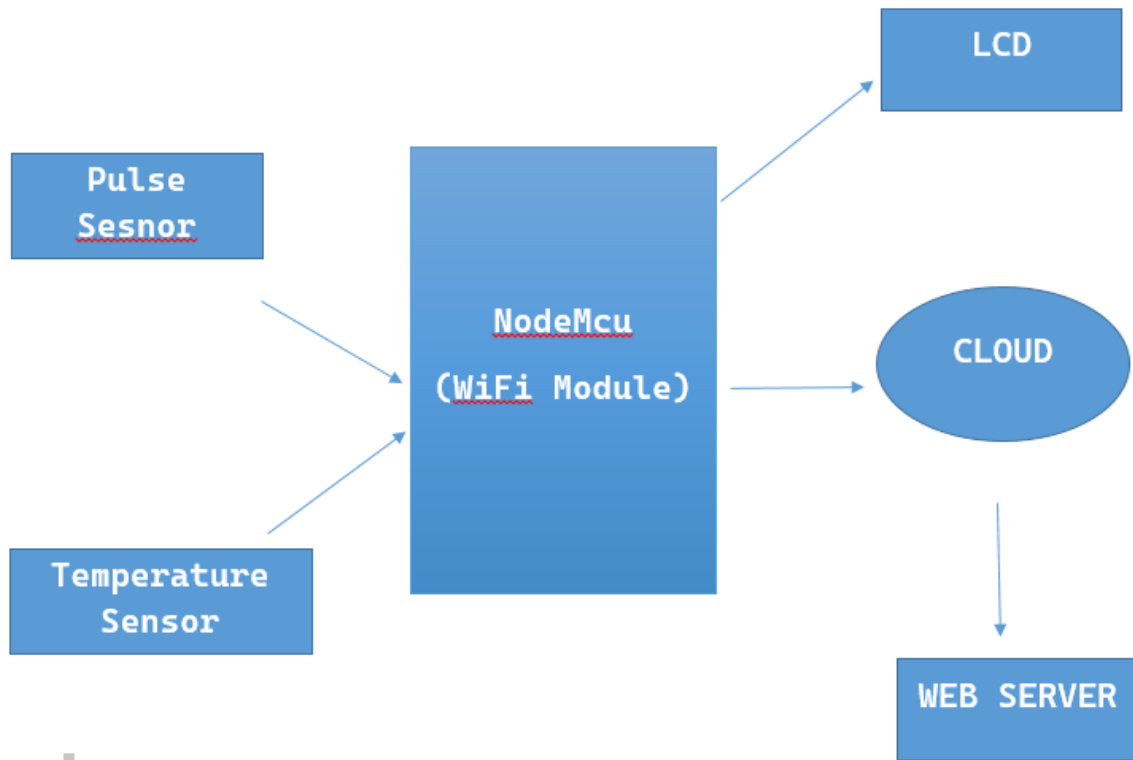

From the diagram above, there are different components coupled together. **The IoT component, the sensors, the screen, the web application and the cloud server.**

The diagrams above depicts the architectural framework of the server side of the web application and its relationship with other applications (IoT and the front-end application). Django Rest framework is the backend web application used on the server side and it follows a modular approach and is used for building Web APIs. It is majorly categorized into modules basically for separation of concerns.

The server side of the web application uses serializers to convert complex data types such as query-sets and model instances from the database, into JSON, XML or other formats. Serializers also handle validation of incoming data and provide a way to handle any errors that occur during data processing. The Viewsets defines the logic for handling incoming HTTP requests and returning the appropriate response. Viewsets are responsible for handling CRUD (Create, Read, Update, and Delete) operations on the data. The presentation layer of the rest framework is the connecting layer between the application and other applications therefore creating an API endpoint for other applications to communicate with this project.

The presentation layer automatically generate URLs for the viewsets (logic side) and this connects with a front end application which is ReactJs in this project. The Front-end application calls this endpoint (API) which is created from the backend and it uses the data rendered to display on the web view for the end users to have a visual/pictorial representation of the project.

In this project, the IoT application sits on one end and the web application (frontend and backend) sits on another end and the two communicates to each other with API call(s) and it returns the result of the data of the patients after it has uploaded the information to the cloud.

This research project uses two diagrams to cut across the interactions of users in the system and also illustrate the connections between various objects in the system.

**USE CASE DIAGRAM**

There are 4 actors in this use case diagrams.

- Doctor
- Nurse (system)
- Patient
- IoT

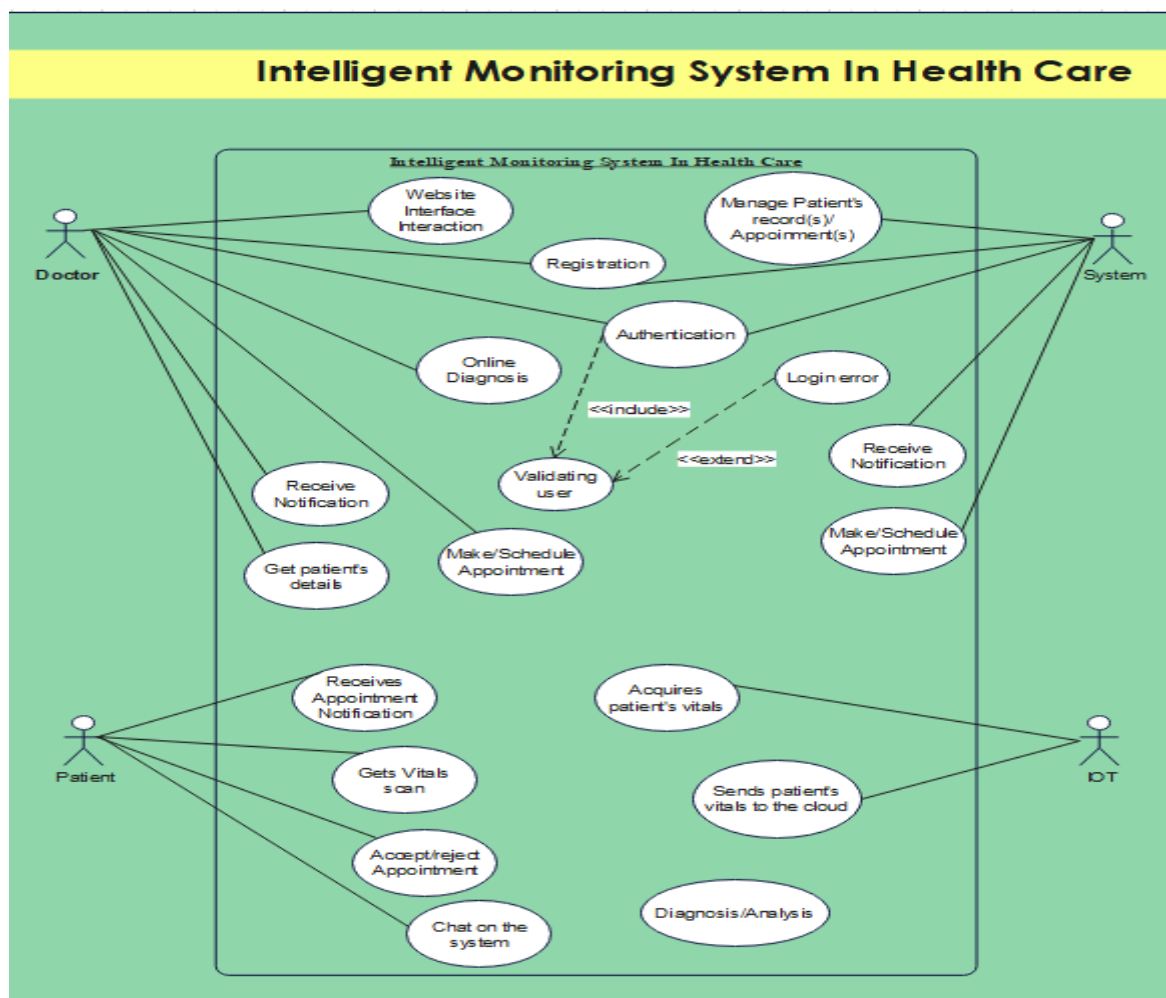

UML CLASS DIAGRAM

IoT UML Class diagram

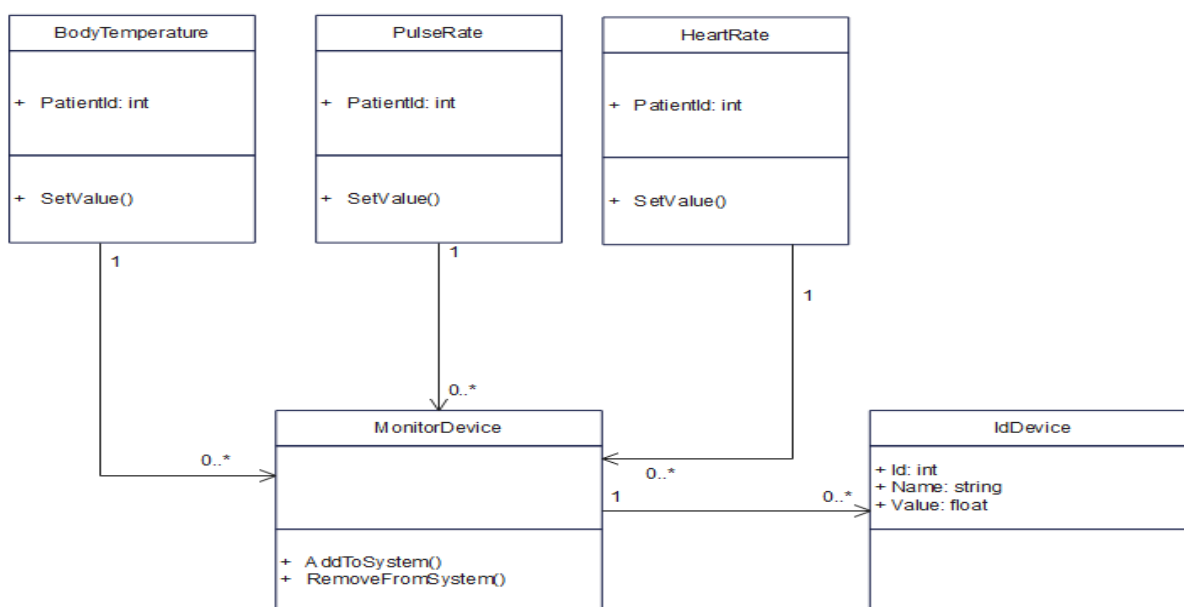

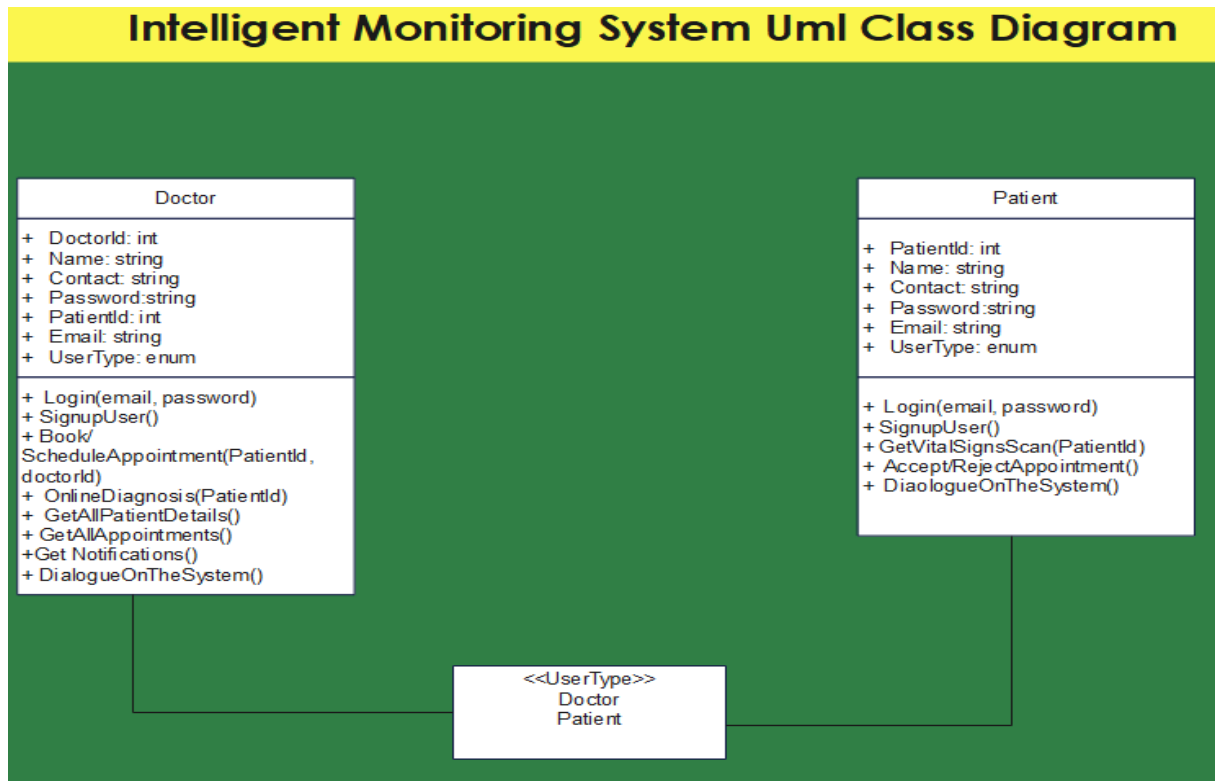

### SYSTEM IMPLEMENTATION

The implementation of this project requires the development of the IoT technology and the Web application:

The internet of things technology used here is the NodeMcu Module, a micro-controller which is the processor on which other devices are connected to. The sensors receives the vitals from the patient and with the NodeMcu (Wifi Module), it uploads the information to the cloud in real-time. On the IoT server, there is a script that reads the information retrieved, on the web application there is an API (GET Request call) to fetch the data (in JSON format) which in return sends it to the front end.

Application programming interface (APIs) were built to interact between the IoT server, the backend application and the front end application. This section reveals the whole process of implementation of the system, through the different components that makes up the system (IoT, backend and frontend application, database).

Primarily, for the system to be efficient and effective to run well it has some basic requirements that must be met which is as follows:

### HARDWARE AND SOFTWARE REQUIREMENTS:

The following requirements are the minimum requirements required for the system to perform optimally.

**IoT APPLICATION (HARDWARE SPECIFICATION):** a high performance processor to handle tasks, Memory to handle data and program execution, Networking for internet connectivity, Sensors to get patients vitals such as temperature and humidity, Power, Accuracy to ensure precise data collection, Interoperability to communicate with other medical devices and systems.

**IoT APPLICATION (SOFTWARE REQUIREMENT):** operating system, a fast internet connection for real time upload, middleware for device management, security features such as encryption, authentication and access control, user interface for device configuration and management, cloud integration with cloud services for remote data storage and processing.

**WEB APPLICATION (BACKEND) SOFTWARE REQUIREMENTS:** For the system to be implemented the software requirement for the backend application are server-side scripting language, Database management system, RESTful Api Design (Django rest framework), Security features (authentication, authorization, encryption, permissions), Scalability and performance optimization, monitoring and logging tools, collaboration and project management tools (GitHub), Testing and debugging tools.



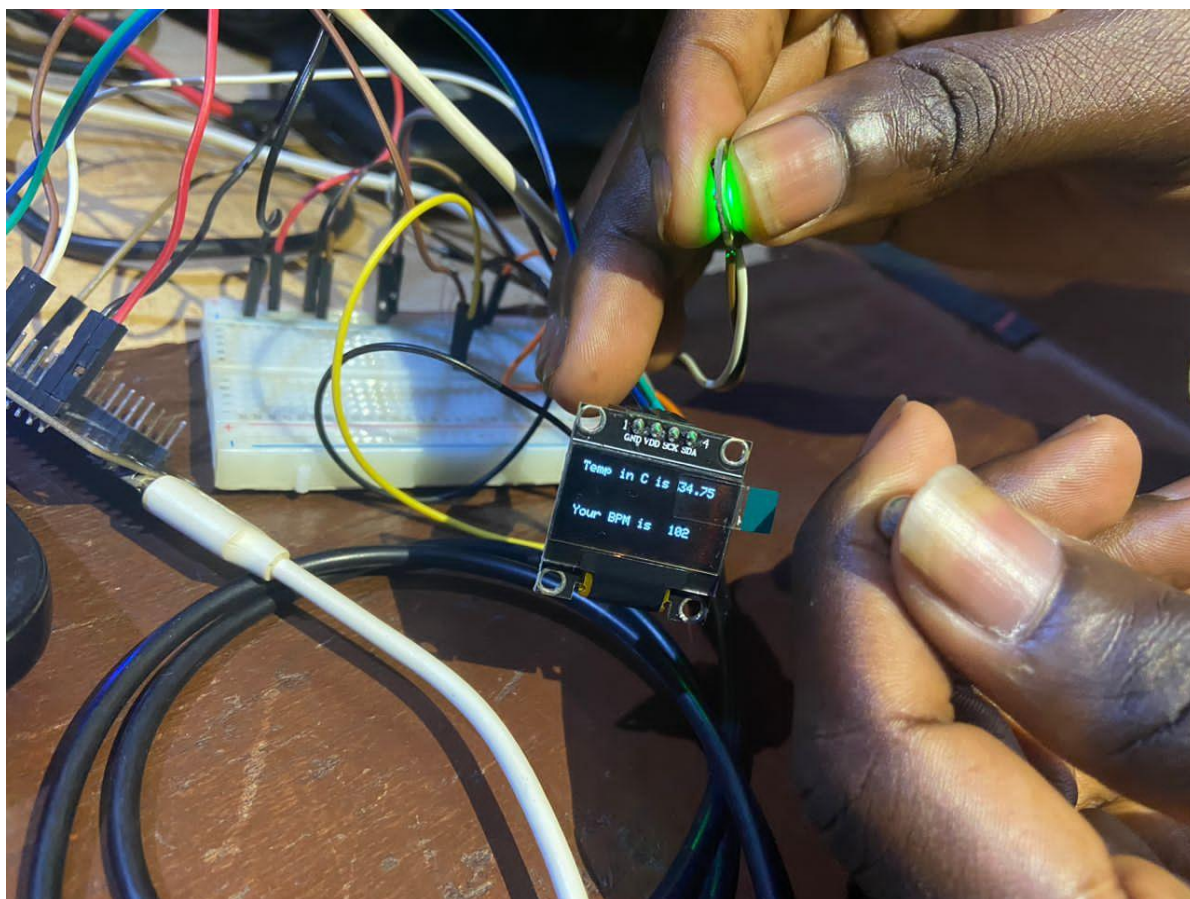

Dashboard

Dashboard

Patient's Reading

Search

ID	BPM	Temperature C	Temperature F	Date Created	Action
99	553	28.56	83.41	09/02/2023	Search
100	545	28.5	83.3	09/02/2023	Search
101	545	28.5	83.3	09/02/2023	Search
102	545	28.56	83.41	09/02/2023	Search
103	543	28.69	83.64	09/02/2023	Search
104	536	28.75	83.75	09/02/2023	Search

READINGS FROM THE IoT SYSTEM

**SYSTEM EVALUATION**

The project is evaluated by checking the stated objectives with what was implemented. At the end of the project, the intelligent monitoring system was evaluated and the following was observed.

The objectives of the project stated at the start of this project were to:

1. To design a health intelligent monitoring system
2. To provide real-time medical diagnosis
3. To provide a database record of patient's health information
4. Scheduling and ticketing of appointments with the doctors and patients.

The performance of the software system and the entire system was assessed using certain appropriate measures. The table below lists a few of them.

The table below displays the evaluation of the various metrics utilized based on interactions between different users (both patients and medical staff) of the system.

S/N	Reliability Metrics	Measure
1	Speed	Real time response, processed transactions
2	Simplicity	Easy to use and understand, seamless user experience and design
3	Reliability	Mean time to failure, availability, back up
4	Efficiency	94% efficient
5	Effectiveness	95% optimal
6	Satisfaction and correction	90% satisfaction
7	Validation	Checks against error and high critical cases
8	Security	Authentication, encryption and authorization are integrated

## II. RESULT AND DISCUSSION

The implementation of this project is categorized into two parts, Internet of Things and the web application. Each of these categories though depends on each other, they provide their individual result. The result of the IoT is needed for the web application to integrate and work upon.

However, each application may be used separately to view the outcome. The LCD panel, which shows the results of the vitals scan, may be used to view the sensors' results. Here, the patient may see the results after the sensors have verified them. A sound that shows the result is serious and requires the doctor's immediate attention is activated if it is critical.

On the other hand of the project (web application), the result is gotten through an API call to the IoT server which returns the results of the patient. This is returned at real time as the patient gets his/her vitals scanned. This is displayed, analyzed and viewed on the web application which the doctor gets to view.

## III. CONCLUSION

First and foremost, this study has shown and identified one of the major concerns in the health sector, which is the delay in attending to patients in hospitals especially public hospitals thereby leading to death. (Kashif et al, 2020). This concern was a motivation for this project.

In this project, a smart technology was incorporated to solve this problem. The study however provided how IoT offers seamless communication across a wide range of devices, including domestic appliances, medical sensors, and surveillance cameras. (P.Gope and T.Hwang, 2015).

Researches were done on related works, but they failed to integrate and implement IoT in the health sector to prevent delay and congestion. However, this project aimed to achieve and solve this stated problem.

In this project and study, an intelligent monitoring system was developed using IoT and a web application. This application was implemented, deployed and tested.

Based on the outcome and the research put in this project, we have seen that IoT is a sought after technology. I strongly recommend that the health sector exploits this technology in solving their problem.

It would be great if machine learning is integrated in this project. This can help stakeholders know the pattern of the vitals reading and recommend a diagnosis which can serve as an assistant to the doctor in real-time. The doctor getting to login to the application before viewing the patient's information can cause delay on critical cases which needs urgent care and response.

More so, other sensors can be bought and integrated to the NodeMcu. These sensors would help to scan more vitals which can help in better diagnosis.

## REFERENCES

- [1]. Azzawi, M. A., Hassan, R., & Abu Bakar, K. A. (2016). A review on Internet of Things (IoT) in healthcare. *International Journal of Applied Engineering Research*, 11(20), 10216-10221.
- [2]. Gope, P., & Hwang, T. (2015). BSN-care: A secure IoT-based modern healthcare system using body sensor network. *IEEE Sensors Journal*, 16(5), 1368-1376.
- [3]. Kashif, M., Farhan, Z., Ali, M., & Qureshi, S. (2020). An intelligent IoT based healthcare system using fuzzy neural networks. *Scientific Programming*, 2020.
- [4]. Mariya Chithra Mary, A., Veerakumar, S., & Babu, R. (2018). Health Monitoring Systems using IoT. *International Journal of Engineering Research & Technology (IJERT)*, IConnect – 2018 (Volume 6 – Issue 07).
- [5]. Mr. Akash M. Rathod, Prof./Dr. G.U. Kharat, & Prof. R.S. Bansode. (2020). IoT Based Patient Monitoring System. *International Journal of Advance Research and Innovative Ideas in Education*, 6(4), 59-63. Nelles, O. (2013).
- [6]. Patil, P., & Mohsin, S. (2013). Fuzzy logic based health care system using wireless body area network. *International Journal of Computer Applications*, 80(12).
- [7]. Sujith, A. V. L. N., Sajja, G. S., Mahalakshmi, V., Nuhmani, S., & Prasanalakshmi, B. (2021). Systematic review of smart health monitoring using deep learning and Artificial intelligence. *Neuroscience Informatics*.

- [8]. Vani, R., & Subitha, D. (2020). Health Monitoring Wearable Device Using Internet Of Things. *European Journal of Molecular & Clinical Medicine*, 7(3), 395-400.
- [9]. Vani, R., Ushabhanu, N., & Sangeetha, M. (2017). Fast motion estimation algorithm using hybrid search patterns for video streaming application. *International Journal of Computers, Communications & Control*, 12(5), 715-727.
- [10]. Vedaci, S. S., Fotovvat, A., Mohebbian, M. R., Rahman, G. M. E., Wahid, K. A., Babyn, P., Marateb, H. R., Mansourian, M., & Sami, R. (2020). COVID-SAFE: An IoT-based system for automated health monitoring and surveillance in post-pandemic life. *IEEE Access*, 8, 188538-188551
- [11]. Whitmore, A., Agarwal, A., & Da Xu, L. (2015). The internet of things-a survey of topics and trends. *Information Systems Frontiers*, 17(2), 261-274.
- [12]. Ghosh, A. M., Halder, D., & Hossain, S. K. A. (2016). Remote health monitoring system through IoT. 2016 5th International Conference on Informatics, Electronics and Vision (ICIEV). <https://doi.org/10.1109/ICIEV.2016.7760135>. Retrieved 4<sup>th</sup> December, 2022