

# Research on crane beam calculation methods to reduce simulation computation time

Hong Tien Nguyen, Dang Ha Le, Duc Cuong Nguyen  
Hanoi University of Industry, Hanoi, Vietnam

---

## Abstract

Cranes are one of the most commonly used lifting equipment, requiring periodic safety assessments to prevent potential incidents. However, current software applications utilize traditional finite element methods, leading to time-consuming simulation computations. There is a lack of optimized simulation computation methods for cranes, especially for crane beam systems. This paper introduces an alternative safety assessment method for cranes, beyond conventional CAE analysis, which is the method of combining Finite Element Analysis (FEA) and Boundary Element Analysis (BEA) techniques using Altair SimSolid software to reduce the preprocessing time for simulation models. The paper analyzes the crane beam model on two popular softwares, NX Simcenter 3D and Altair Simsolid, to evaluate the safety of the crane, compare the calculation time and results of the two software, thereby providing recommendations for selecting simulation software achieve reduced simulation computation time compared to traditional Finite Element Methods and conventional meshing approaches.

**Keywords:** Crane, CAE, Simulation, Simcenter 3D, Simsolid, Time optimization.

---

Date of Submission: 25-06-2024

Date of acceptance: 04-07-2024

---

## I. INTRODUCTION

Cranes are widely used in the machinery industry, industrial and mining enterprises and other industries and play an important role in national production. They offer advantages such as high load-bearing capacity, reliability, and relatively simple manufacturing processes. With the continuous development of cranes with high load capacity, high specifications, low noise, minimal vibration and smooth operation, current products need precise calculations, and the computation time is significant to meet market demands.

Currently, many researchers have turned their attention to delving into the study of crane loadings. Xiong and colleagues applied finite element analysis and simulation to investigate the box beam structure of a heavy material lifting machine [1]. Yuan and his team performed three-dimensional modeling analysis on the structure of a heavy material lifting machine [2]. In addition, researchers are also interested in the aspect of fatigue life of cranes [3-4]. The concentration on computation and optimization of computation time alongside load testing simulation in software has not been extensively addressed by the mentioned authors. Therefore, in this paper, we propose two software, Altair Simsolid and NX Simcenter 3D, to evaluate the computation time and compare results between them. Simcenter 3D uses traditional finite element methods (FEM) to simulate structures and mechanical systems similar to current software, while SimSolid, Altair Engineering's new product, employs a combination of Finite Element Analysis (FEA) and Boundary Element Analysis (BEA) to reduce preprocessing time, marking a breakthrough in mechanical simulation. It stands out with a meshless simulation approach and rapid computation time. This allows us to provide alternative solutions and propose different computational approaches compared to traditional methods, aiming to reduce simulation computation time, especially for crane beam systems.

## II. THEORETICAL BASIS

### 2.1. Overview of crane beam structure

Cranes, one of the most important tools in the field of lifting and transporting materials, play an important role in today's market. The overall structure of a crane includes main beam, double side beam, steel cables and electric winch. During operation, the main beam of the crane moves along the overhead rails, while the double auxiliary beams perform horizontal movements on the main beam's rails. This configuration creates a rectangular working scope, allowing the crane to efficiently utilize space for lifting and transporting materials [5].

**2.1.1 Selection of Beam Cross-Section**

Beam is a basic structural element which is primarily subjected to maximum bending in the middle and maximum shear at the beam's ends. We choose a box beam with a span of 12 meters because it has good resistance to bending moments and torsional moments. The material selected for fabricating the beam is C45 steel with the following parameters:

- Density:  $\gamma = 7,82 \text{ kG/m}^3$ .

**Table 1. Chemical composition of C45 steel**

Steel grade	Elemental composition %						
	C	Si	Mn	P	S	Cr	Ni
C45	0,42-0,50	0,17-0,37	0,50-0,80	0,040	0,040	0,25	0,25

\* Determining the beam cross-sectional height

- The cross-sectional height of the beam is a fundamental parameter in beam design, determined by the formula:

$$h = \left( \frac{1}{18} \div \frac{1}{14} \right) \cdot l \cdot (667 \div 857) \text{ mm} \tag{1}$$

- Length of the beam end and inclined chamfer:

$$C = (0,1 \div 0,2) \cdot l$$

- Height of beam at support section:

$$H1 = (0,4 \div 0,6) \cdot h$$

- Width of upper border bar:

$$B = (0,3 \div 0,5) \cdot h$$

- To ensure the stiffness of the beam, the width B' between the flanges is selected using the formula:

$$B' = \left( \frac{1}{40} \div \frac{1}{50} \right) \cdot l$$

With h: Beam cross-sectional height

l: Preliminary length of the beam

C: Length of the beam end and inclined chamfer

H1: Height of beam at support section

B: Width of upper border bar

B': Width between the flanges

**Table 2. Preliminary dimensions of the beam**

Dimension	Cross-sectional height	Length of the beam end and inclined chamfer	Height of beam at support section	Width of upper border bar	Width between the flanges
Parameter	(667 ÷ 875)	(1200 ÷ 2400)	(320 ÷ 240)	(375 ÷ 400)	(240 ÷ 300)

**2.1.2 Cross-sectional beam test**

- The allowable stress in the structure is:

$$[\sigma] = \frac{\sigma^c}{n} = \frac{240}{1,4} = 171,4 \text{ N/mm}^2 = 1714 \text{ kg/cm}^2$$

$$[\tau_c] = 0,6 [\sigma_c] = 0,6 * 240 = 144 \text{ N/mm}^2 = 1440 \text{ kg/cm}^2$$

- Determine the load acting on both ends of the beam

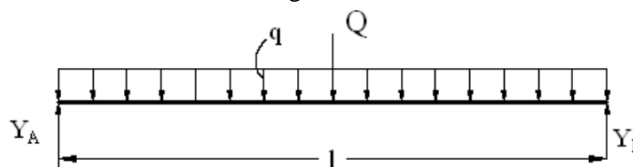

**Figure 1. Load diagram acting on the main beam**

We have:  $\sum F_y = 0 \Leftrightarrow Y_A + Y_B - Q - Q_d = 0$   
 $\Leftrightarrow Y_A + Y_B = Q + Q_d = 5000 + 530 = 5530$  (1)

$$\sum M_{(F,A)} = 0 \Leftrightarrow Y_B * 1 - (Q + Q_d) * \frac{1}{2} = 0$$

$$\Leftrightarrow Y_B = (Q + Q_d) * \frac{1}{2} = 5530 * \frac{1}{2} = 2765$$
 (2)

From (1) and (2), it follows that  $Y_A = Y_B = 2765$  kg

At the two ends of the beam, the stress is maximum.

$V_{max} = Y_A = Y_B = 2765$  kg

We observe,  $\sigma_u \leq [\sigma] = 1714 \Rightarrow$  Satisfies the durability condition

## 2.2. Classification of main beams in bridge crane structures

### 2.2.1 Main girder of a single-girder bridge crane

The main beam is typically fabricated from I-shaped steel beams. The dimensions of the I-shaped steel beam are selected to ensure strength, stiffness, and stability. These dimensions are calculated based on the lifting load, span, and the hoist's ability to move along the lower flange of the beam. Additionally, it is necessary to check the lateral stiffness of the beam in specific working conditions. In cases where the beam lacks sufficient strength and stability, additional stiffness can be achieved by welding additional bracing bars to the upper edge of the main beam.

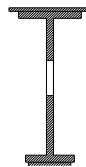

Figure 1. I-shaped beam structure

Typically, single beam cranes use I-beam main beam and are suitable for crane types with spans up to 12 meters, lifting capacities up to 10 tons, and can be manually or electrically operated.

### 2.2.2 Main beam of double beam overhead crane

The simplest structure for a double beam overhead crane involves using two parallel I-beam beams with end carriages mounted on top of the beams. The I-beams have tracks for the trolley to move along. The main beam is connected to the end carriages through welding or bolts.

For types with larger lifting capacities, I-beams are often used but reinforced with a working platform surface and guardrails on both sides. Another common variation is to use continuously welded steel plates, forming a box structure with three open sides. This type typically includes a vertical plate, an upper plate, and a lower plate (See Figure 2).



Figure 2. Main beam with 3 open sides

## III. BUILDING COMPUTATIONAL MODEL

### 3.1 Establishing objectives and input parameters for beam 1

The simulation method employed here is to examine the results and simulation time of two software applications, assessing the computation time and outcomes of both. Subsequently, determining which software is optimal and more efficient.

a) Model and Input Parameters

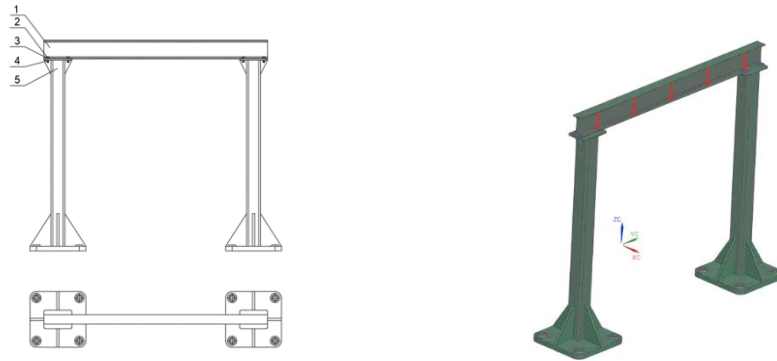

Figure 3. Beam 1

1. Beam; 2. Bolt ; 3. Washer; 4. Nut ; 5. Base Plate

b) Input data

Crane beams are used to lift and lower materials in the factory, so we use C45 steel.

Table 4. Dimensions of the crane beam 1

Beam length	Beam height	Beam width	Base plate's length	Base plate's width	Beam load	Model weight
2400 mm	200 mm	100 mm	2065 mm	150 mm	1500 kg	56,87 kg

3.2 Establishing objectives and input parameters for beam 2

The simulation method employed here is to examine the results and simulation time of two software applications, assessing the computation time and outcomes of both. Subsequently, determining which software is optimal and more efficient.

a) Model and Input Parameters

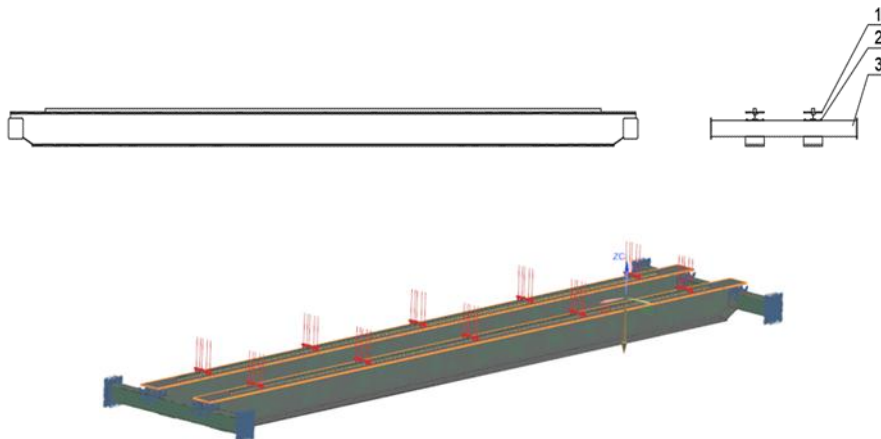

Figure 4. Beam 2

1. Beam.; 2. Bolt ; 3. Beam support

b) Input data

Crane beams are used to lift and lower materials in the factory, so we use C45 steel.

**Table 2. Dimensions of the crane beam 2**

Beam length	Beam height	Beam width	Beam support's length	Beam support's width	Beam load	Model weight
9000 mm	440 mm	270 mm	2111 mm	150 mm	3000 kg	233,36 kg

**IV. RESEARCH RESULTS**

**4.1 Simulation results of crane beam 1**

a) Calculation using Simcenter 3D software

**Table 4. Results on Simcenter 3D**

Analysis	Time
Automatic mesh generation by software	28 second
Model computation	50 second
Total computation time	78 second

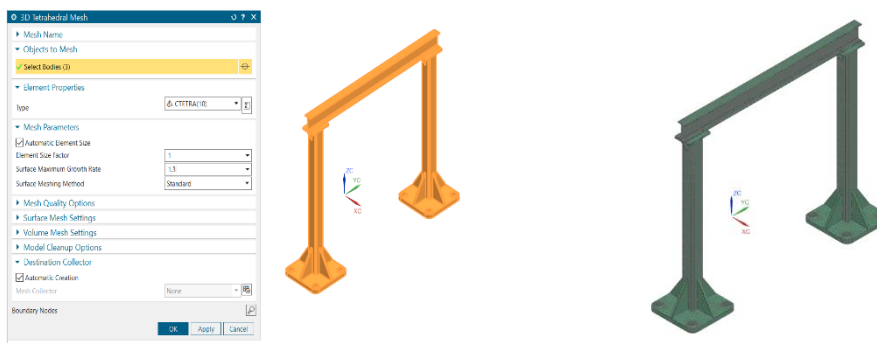

**Figure 5. Automatic mesh generation by software**

b) Calculation using Simsolid software

For SimSolid software, there is no need to perform meshing; instead, boundary conditions are assigned, forces are applied, and structural analysis is conducted for stability checks.

**Table 5. Results on Simsolid**

Analysis	Time
Computation using software	3 second

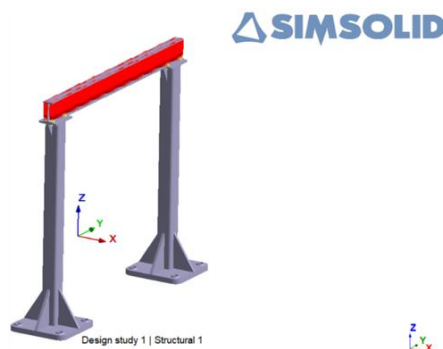
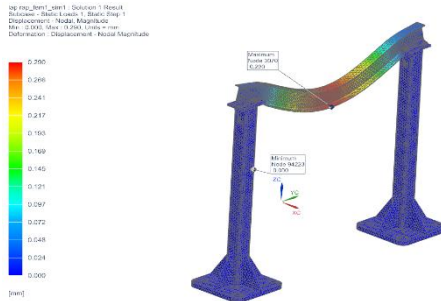

**Figure 6. Set boundary conditions and apply forces.**

**Results:**

**Table 6. I-beam test results**

Software	Simcenter 3D	Simsolid	Difference (%)
Result			
Displacement	Max: 0,29 N.mm Min: 0 N.mm	Max: 0,29 N.mm Min: 0,000001 N.mm	0%
Time	78 second	3 second	26 times



**Figure 7A. Results of displacement on Simcenter 3D software.**

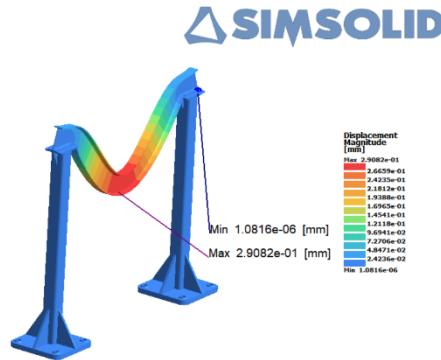

**Figure 7B. Results of displacement on Simsolid software.**

Conclusion: When comparing the stability analysis time between the two software, we observe that for Simcenter 3D, it is 78 seconds, whereas for SimSolid, it is only 3 seconds. The computation time with SimSolid is 26 times faster than when computed using Simcenter 3D.

**4.2 Simulation results of crane beam 1**

a) Calculation using Simcenter 3D software

**Table 7. Results on Simcenter 3D**

Analysis	Time
Automatic mesh generation by software	20 seconds
Model computation	69 seconds
Total computation time	89 seconds

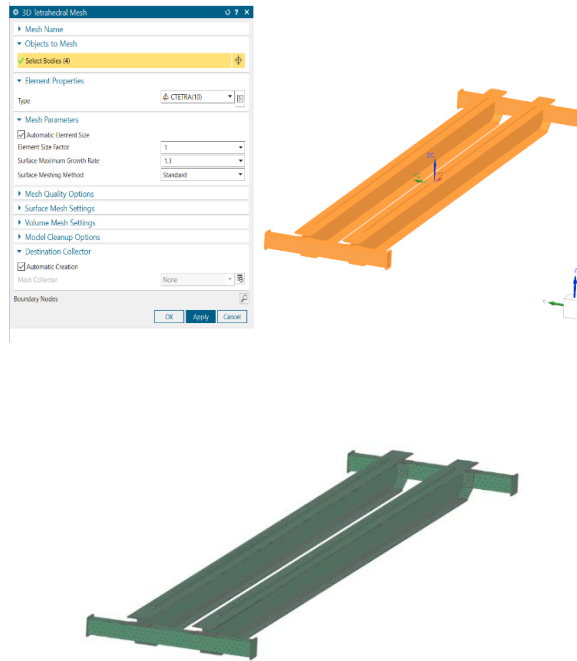

Figure 8. Automatic mesh generation by softwar

b) Calculation using Simsolid software

- For SimSolid software, there is no need to perform meshing; instead, boundary conditions are assigned, forces are applied, and structural analysis is conducted for stability checks.

Table 8. Results on Simsolid

Analysis	Time
Computation using software	3 seconds

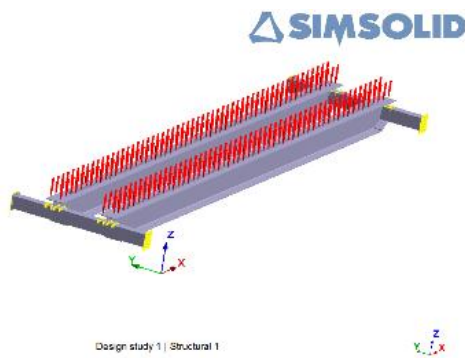

Figure 9. Set boundary conditions and apply forces.

Results:

Table 9. II-beam test results

Result \ Software	Simcenter 3D	Simsolid	Difference (%)
Displacement	Max: 1,569 N.mm Min: 0 N.mm	Max: 1,547 N.mm Min: 0,0000004 N.mm	1%
Time	89 seconds	3 seconds	29 times

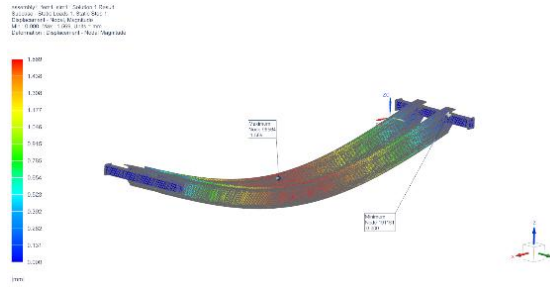

Figure 10A. Stress and displacement results using Simcenter 3D software

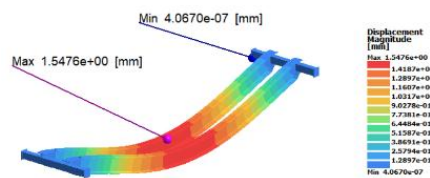

Figure 10B. Stress and displacement results using Simsolid software

Conclusion: The stability analysis results between the two software show similar stress and displacement patterns. However, the total simulation computation time yields a significant difference. Simcenter 3D takes 89 seconds, while SimSolid only takes 3 seconds. This indicates that the computation time with SimSolid is 29 times faster than when computed using Simcenter 3D.

#### 4.3 Conclusion

- By presenting the calculation results of the two examples above, it is evident that SimSolid software is more optimized in terms of computation time compared to Simcenter 3D, with a discrepancy of approximately 1% between the two.

- Through the optimization of computation time, this study provides an efficient computational solution compared to other software, saving time in the research process. This is particularly valuable for problems involving beam systems and frameworks where meshing consumes a significant amount of time.

- The application of this innovative method, combined with modern simulation, helps bridge the gap between theory and practice, offering precise and efficient technical solutions for assessing the safety of overhead cranes.

#### REFERENCES

- [1]. G Xiong, X Luo, Y H Luo et al. Fracture analysis and finite element simulation of crane box girder structure containing defects. *J. Machinery Design&Manufacture*, 2016(4): 207-210.
- [2]. K Yuan, Q F Fu, X Z Qu, et al. Analysis of large complex hoisting machinery structure of three - dimensional finite element model of substructure. *J. Machinery Design&Manufacture*, 2015(3): 14-18.
- [3]. L Chen, L S Liu, L Q Ling. Software system development and engineering application for fatigue life analysis and prediction of crane. *J. Journal of Safety Science and Technology*, 2016, 12(9): 138-145.
- [4]. X Wu, W Luo, L Liu, et al. Prediction of metal structure fatigue life of bridge and gantry crane in service. *J. China Safety Science Journal*, 2010, 20(2): 95-99.
- [5]. X L Liao<sup>1</sup>, Y L Liu<sup>1</sup>, S J Fang<sup>1</sup>, X J Cheng<sup>1</sup>, S Chen<sup>2,\*</sup> and Y B Sun<sup>3</sup> F.: Research on loading experimental method of bridge crane without hoisting weight. In: *The 2nd International Workshop on Materials Science and Mechanical Engineering*, pp. 1. *Materials Science and Engineering* 504 (2019).