

Combined Perturb and Observe and Artificial Neural Network Approach for Maximum Power Point Tracking in Photovoltaic system under uniformly shaded conditions.

K.V.Subathra

Assistant professor

Amrita College of Engineering and Technology, Nagercoil, Kanya Kumari DT (TN), 629901. India

subathrakv@gmail.com,

Abstract: *Maximum Power Point Tracking (MPPT) of PV system is very much essential for the efficient operation of the solar photovoltaic (PV) system. PV system performance mainly depends on solar insolation and temperature conditions. In this paper combination of Perturb and Observe (P&O) and Artificial Neural Network (ANN) MPPT algorithms is proposed to provide reference voltage to DC-DC boost converter in the PV system under uniform shading conditions. In ANN- based techniques, the maximum power points are acquired by designing ANN models for PV modules. Compared to conventional P&O MPPT method, this approach tracks to the Maximum Power Point (MPP) faster with less fluctuations. The training of the ANN is done with Levenberg Marquardt algorithm and the whole technique is being simulated and studied using MATLAB software.*

Keywords –MPPT; Photovoltaic; Artificial Neural Network; Back-propagation;

Date of Submission: 26-07-2022

Date of acceptance: 09-08-2022

I. INTRODUCTION

At present worldwide including Indonesia have energy crisis so that the necessary renewable energy as a replacement. One of renewable energy namely solar energy has the greatest potential in Indonesia in the amount of 156.487 MW and utilized for the new 5MW. The freely and abundantly available solar energy can be easily converted into electrical energy using PV cells [1]. Since PV sources exhibit nonlinear I-V characteristics, their power output mainly depends on the nature of the load. So, direct load connections to PV systems result in poor overall efficiency. As solar panels are still expensive, minimizing the cost of their life cycle has recently become an important consideration. Therefore, a Maximum Power-Point Tracker (MPPT) is required to handle such problems and ensure that the PV system is operating at the Maximum Power Point (MPP). Many different MPPT Techniques have been proposed, with the objective of reducing the hardware and improving the performance of the PV system [2, 3].

The general requirements for maximum power point tracker (MPPT) are simple and low cost, quick tracking under condition change, and low output power fluctuation. It is necessary to solve this problem by using a more efficient method. Neural Network technology has attracted widespread interest in electrical engineering. Neural network modeling does not require any physical definitions for a PV array. Many number of algorithms available for the MPPT including perturb and observe, incremental conductance, parasitic capacitance, constant voltage, fractional open circuit voltage and fuzzy logic algorithms. These methods have disadvantages like costly, difficult to implement and non-stable.

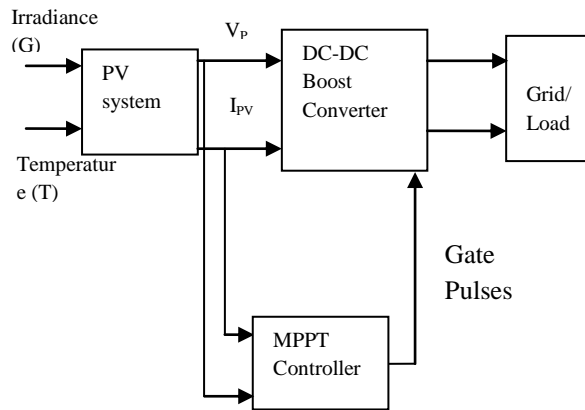

Fig. 1. Block diagram of a PV system.

A drawback of P&O MPPT algorithm is that, during steady state, the operating point oscillates around the MPP giving rise to the wastage of energy. Many improvements of the P&O algorithm have been proposed in order to reduce the number of oscillations around the MPP, but they slow down the speed of response of the algorithm to varying atmospheric conditions and decrease the algorithm efficiency during cloudy days. These problems can be overcome by using ANN. ANN is suitable to handle non-linearity, uncertainties and parameter variations in a controlled environment. Hence many number of ANN algorithms have been developed for this purpose [4, 5, and 6].

The uses of neural network in the industrial electronics have been increased, and have a large perspective in intelligent control area [7]. In this paper an ANN based MPPT is presented and trained with LM (Levenberg-Marquardt) algorithm and the Back propagation method to extract the optimal voltage of the PV array which also decreases the tracking time to reach the MPP. The simulations are carried out to validate the proposed ANN method.

II. PV SYSTEM MODEL

The Block diagram of a PV system is shown in Fig. 1. A PV cell can be represented by an equivalent circuit as shown in Fig. 2. A PV array consists of several photovoltaic cells connected in series and parallel. To increase voltage or amperage of a solar system, the solar panels can be placed in series (higher voltage) or parallel (higher amperage) or a combination of both. The characteristics of this PV cell can be obtained using standard equations .

The V-I characteristic equation of a solar cell is given as follows,

$$I = I_{ph} - I_s \left[\exp\left(\frac{q(V + IR_s)}{kT_c A}\right) - 1 \right] - (V + IR_s) / R_{sh} \quad (1)$$

Where I_{ph} is a light-generated current or photocurrent, I_s is the cell saturation current, q ($= 1.6 \times 10^{-19}C$) is an electron charge, k ($= 1.38 \times 10^{-23}J/K$) is a Boltzmann's factor, T_c is the temperature of a solar cell, A is an idealist factor for a p-n junction, R_s , R_{SH} are the series and shunt resistances respectively. The photocurrent mainly depends on the solar irradiation and the temperature which is given as,

$$I_{ph} = [I_{sc} + k_I(T_c - T_{ref})]\lambda \quad (2)$$

Where I_{sc} is the cell's short-circuit current at a $25^{\circ}C$ and $1kW/m^2$, K_I is the cell's short circuit current temperature coefficient, T_{ref} is the reference temperature of a solar cell, and λ is the solar insolation in kW/m^2 . On the other hand, the saturation current varies with temperature, which is described as

$$I_s = I_{rs}(T_c - T_{ref})^3 \exp\left[\frac{qE_G(1/T_{ref} - 1/T_c)}{kA}\right] \quad (3)$$

Where I_{RS} is the reverse saturation current of a solar cell at a reference temperature and a solar irradiation, E_G is the band-gap energy of the semiconductor used in the cell. The idealist factor A is dependent on PV technology.

III. MPPT ALGORITHMS.

A typical solar panel converts only 30 to 40 percent of the incident solar irradiation into electrical energy. Maximum power point tracking is used to improve the efficiency of the solar panel. Several approaches have been proposed for tracking the MPP. Among those methods, the perturb and observe (P&O) and

incremental conductance (INC) methods are widely used in spite of its oscillations around MPP and confusion by rapidly changing atmospheric conditions [8].

A. Perturb and Observe method

In this method, the controller adjusts the voltage by a small amount from the array and measure power. If the power increases, further adjustments in that direction are tried until power does not increases. This is called the perturb and observe method. P&O is the widely used MPPT method due to its ease of implementation. This method will result in high- level efficiency. The flow chart of this algorithm is depicted in Fig.3.

The advantage of the P&O method is simple structure, easy implementation and less required

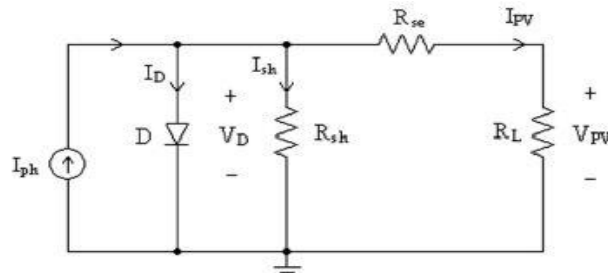

Fig. 2. Electrical equivalent circuit model of a solar PV module

Parameters [9]. The shortcomings of the P&O method can be summarized as follows:

1. The power tracked by the P&O method will oscillate and perturb up and down near the maximum power point. The magnitude of oscillations is determined by the magnitude of variations of the output voltage.
2. There is a misjudgment phenomenon for the P&O method when weather conditions change rapidly.

B.The ANN-Model Based MPPT Algorithm

Neural Network has the potential to provide an improved method of deriving non-linear models which is complementary to conventional techniques. It is trained to derive non-linear PV array model and MPPT using back propagation and Radial basis function.

Back propagation an abbreviation for “backward propagation of errors”, is a common method of training artificial neural networks. It is an example of nonlinear layered feed-forward networks. Back propagation neural networks construct global approximations to nonlinear input-output mapping. The network has three layers, i.e. input, hidden and output layers. The input layer receives the external data, the second layer (hidden layer) contains several hidden neurons which receive data from the input layer and send them to the third layer (output layer), which responds to the system. The weights and biases of the network are adjusted in order to move the network output closer to the targets. All the layers of neural network have a hyper tangent sigmoid transfer function. The Architecture of Back-propagation Neural network for PV array modeling and MPPT tracking having two inputs, three neurons in the hidden layer and one output is shown in Fig.4. [4]. The ‘newff’ function creates a feed-forward back propagation network. It allows a user to specify the number of layers, the number of neurons in the hidden layer and the activation function used [7]. Under uniform shading conditions, the ANN is using the measurement voltage and power of PV is the input of ANN, the output is the reference voltage that the PV obtains the maximum power at.

In the ANN based MPPT method, it has two stages to track the MPP. These two stages are operated alternatively. In the first stage, the trained ANN has guided (V_{ref} , I_{ref}) to optimal point (V_{opt} , I_{opt}) which is close to MPP quickly and in the second stage the P&O is used to track the MPP exactly [11]. The Algorithm for the proposed method is described in Fig. 5.

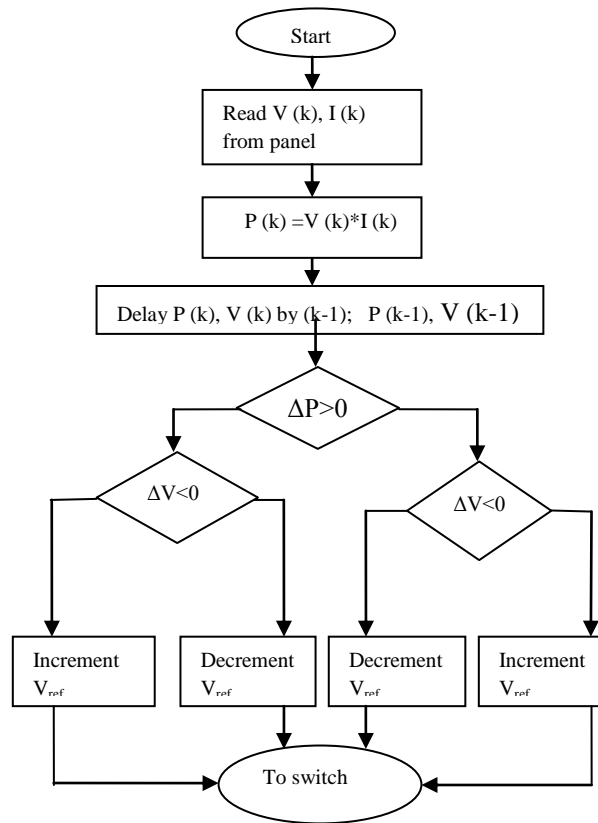

Fig.3. Flow chart of P&O Algorithm.

The training data are determined by using Matlab/Simulink to simulate the PV array. The net is obtained by training with trainlm function – Levenberg – Marquardt algorithm. After training, the network weights are set by the back-propagation learning rule. The weights and biases of the network are adjusted in order to move the network output closer to the targets. The Simulink block of an ANN is shown in Fig. 6.

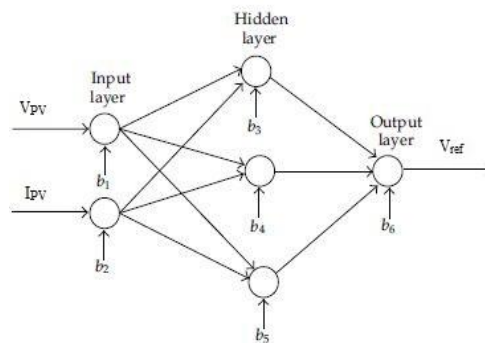

Fig.4. Architecture of Back-propagation neural network.

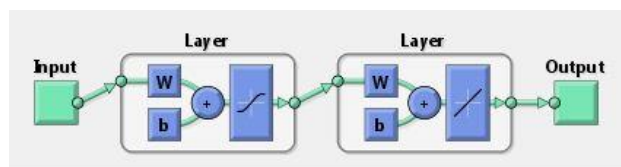

Fig.5. Back-propagation neural network for MPPT.

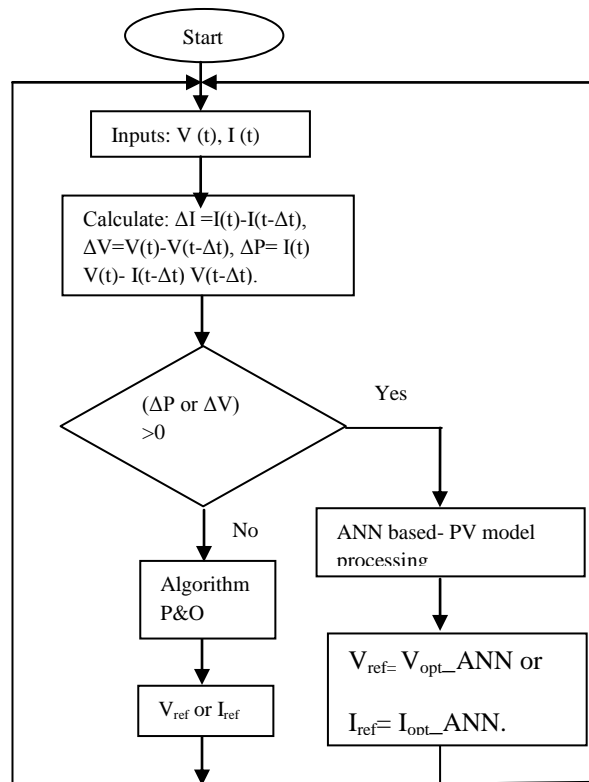

Fig.6. Flow chart of proposed ANN based Algorithm.

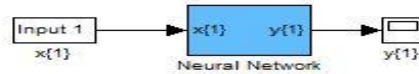
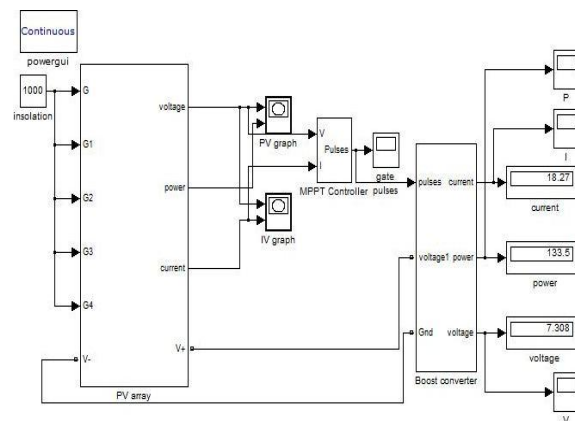

Fig.7. Simulink Block of an ANN

IV. SIMULATION RESULTS AND DISCUSSIONS

The Overall Simulink diagram of a PV system is shown in Fig. 8. Simulation studies have been carried out to verify the proposed Artificial Neural Network method and the results are presented. An accurate PV module electrical model is demonstrated in Matlab/Simulink. The PV and IV Graph under constant irradiance and temperature are shown in Fig.9.

Simulation of closed loop boost converter for solar installation is done using Matlab/Simulink and the results are verified. The closed loop system is able to maintain constant voltage. This converter has advantages like minimized hardware and good output voltage regulation [10]. The proposed method tracks to the MPP faster than the conventional P&O algorithm method track to the MPP in 0.15s but the P&O algorithm tracks to the MPP in 0.42s.



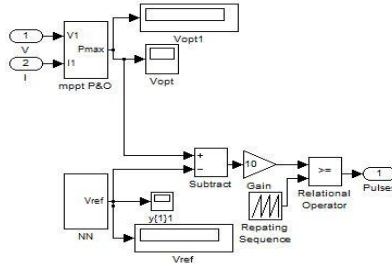
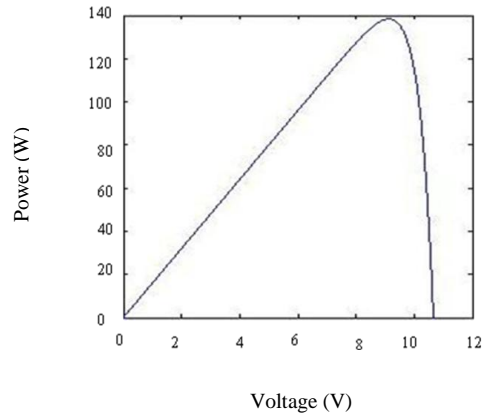
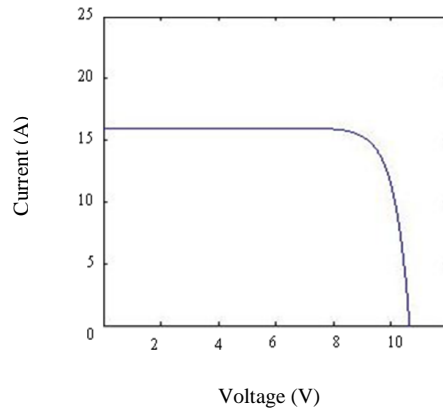

Fig.8. MATLAB/SIMULINK arrangement of entire PV system.



(a)



(b)

Fig.9. Characteristics of a PV module under uniform Insolation (a)PV characteristics (b) IV characteristics. The performance plot of ANN is shown in Fig. 10. Fig. 11 shows the maximum power and optimal voltage outputs of MPPT.

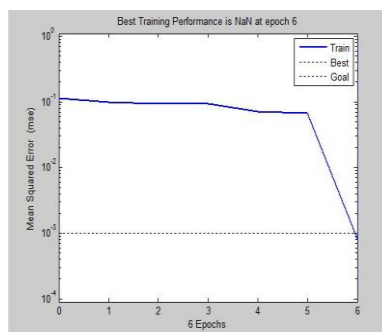
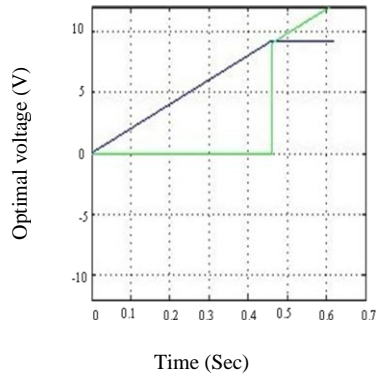
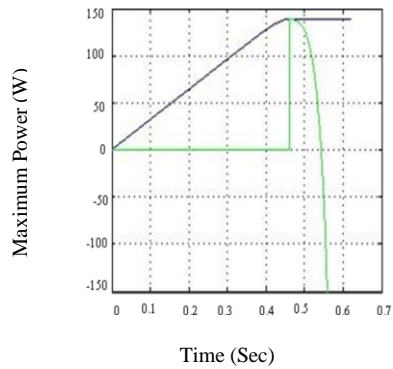

Fig.10. Performance plot of ANN



(a)



(a)

Fig.11. Outputs of MPPT (a) Optimal Voltage (b) Maximum Power

Table 1. Comparison of Conventional and Proposed Techniques:

S.No	MPPT Techniques	Voltage (V)	Current (A)	Power (W)	Time to track MPP (sec)
1	Conventional P&O	9.254	17.45	125.4	0.42
2	ANN based P&O	9.33	18.27	133.5	0.15

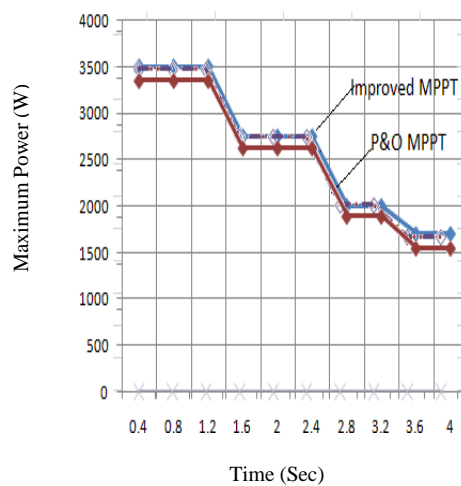

(a)

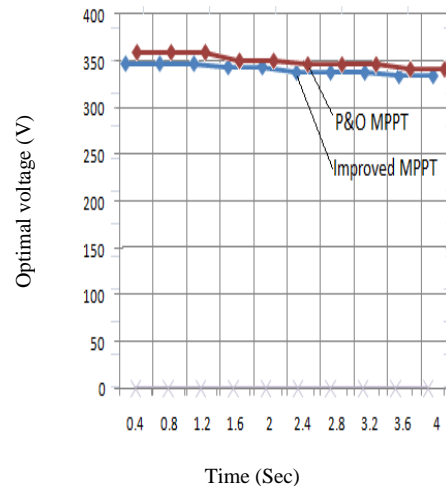

(b)

Fig.12. Comparison of conventional and improved MPPT Techniques (a) Maximum power comparison (b) Optimal voltage comparison

V. CONCLUSION

This paper presents a Maximum Power Point Tracking (MPPT) controller based on Artificial Neural Network. A Matlab/Simulink model is used for photovoltaic system for uniform shading conditions. The error of P&O output (optimal voltage) is compared with the ANN output (reference voltage) and it is again compared with the repeating sequence to generate the gate pulses which is used to drive the DC-DC Boost converter. Compared to conventional MPPT techniques, the proposed ANN-based MPPT method can converge to target MPP very fast and track it without any oscillations as shown in Fig.12.

ACKNOWLEDGEMENT

I would like to acknowledge everyone who helped me in completing this work.

REFERENCES

- [1]. Ratna Ika Putri and M.Rifa'I," Maximum Power Point Tracking Control for Photovoltaic System Using Neural Fuzzy", International Journal of Computer and Electrical Engineering, Vol.4, No.1, February 2012.
- [2]. Bader N. Alajmi, Khaled H. Ahmed, Stephen J. Finney, and Barry W. Williams, 'Fuzzy-Logic-Control Approach of a Modified Hill-Climbing Method for Maximum Power Point in Microgrid Standalone Photovoltaic System', IEEE Transactions on power electronics, VOL.26, NO.4, April 2011.
- [3]. Hiren Patel and Vivek Agarwal,' Maximum Power Point Tracking Scheme for PV Systems Operating Under Partially Shaded Conditions', IEEE Transactions on Industrial electronics, VOL.55, NO.4, April 2008.
- [4]. S. Premrudeepreechacharn, and N. Patanapirom, " Solar-Array Modelling and Maximum Power Point Tracking Using Neural Networks", paper accepted for presentation at 2003 IEEE Bologna power Tech conference, June 23th-26th, Bologna, Italy.
- [5]. Nicola Femia, Giovanni Petrone, Giovanni Spagnuolo, and Massimo Vitelli,' Optimization of Perturb and Observe Maximum Power Point Tracking Method', IEEE Transactions on power electronics VOL.20, NO.4, July 2005.
- [6]. R.Ramaprabha, B.L.Mathur, "Intelligent Controller based Maximum Power Point Tracking for Solar PV System", International Journal of Computer Applications (0975 – 8887) Volume 12– No.10, January 2011.
- [7]. Abdessamia Elgharbi, Dhafer Mezghani, Abdelkader Mami,'A Maximum power point Tracking method based on Artificial Neural Network for a PV system', International Journal of Advances in Engineering & Technology, Nov. 2012.
- [8]. S.Gomathy, S.Saravanan, Dr. S. Thangavel,'Design and Implementation of Maximum Power Point Tracking (MPPT) Algorithm for a Standalone PV System', International Journal of Scientific & Engineering Research Volume 3, Issue 3, March, 2012.
- [9]. Hamed Taheri, Zainal Salam, Kashif Ishaque & Syafaruddin 'A Novel Maximum Power Point Tracking Control of Photovoltaic system Under Partial and Rapidly Fluctuating Shadow Conditions Using Differential Evolution', IEEE symposium on Industrial Electronics and applications (ISIEA 2010), October 3-5, 2010.
- [10]. Athimulam Kalirasu, Subharensu Sekar Dash.'Simulation of closed Loop Controlled Boost Converter for Solar Installation', Serbian Journal of Electrical Engineering, VOL.7, NO.1, May 2010.
- [11]. Hong Hee Lee, Le Minh Phuong, Phan Quoc Dzong, Nguyen Truong Dan Vu, Le Dinh Khoa, "The New Maximum Power Point Tracking Algorithm using ANN-Based Solar PV Systems", IEEE TENCON, 2010.
- [12]. Masafumi Miyatake, Mummadi Veerachary, Fuhito Toriumi Nobuhiko Fujii, Hideyoshi Ko , " Maximum Power Point Tracking of Multiple Photovoltaic Arrays: A PSO Approach", IEEE Transactions on Aerospace and Electronic Systems vol.47.No.1 January, 2011.
- [13]. J.Surya Kumari, Dr.Ch.Sai Babu, A.Kamalakar Babu, 'Design and Analysis of P&O and IP&O MPPT Techniques for Photovoltaic System', International Journal of Modern Engineering Research (IJMER) Vol.2, Issue.4, July-Aug, 2012.
- [14]. Trishan Efram, Patrick L. Chapman, 'Comparison of Photovoltaic Array Maximum Power Point Tracking Techniques', IEEE Transactions on energy conversion, VOL.22, NO.2, June 2007.