

## Analysis of Inclinometer in Foundation Pit

Zhang Liwen<sup>1</sup>, Li Rongzheng<sup>2</sup>, Hu Lei<sup>3</sup>

<sup>1</sup>( College Of Electronic And Electrical Engineering, Shanghai University Of Engineering Science, Shanghai 201620, China)

---

**ABSTRACT:** The inclinometer has a very important significance in the foundation pit engineering. The inclinometer can obtain the horizontal displacement in the deep soil of the foundation pit by measuring the change of the angle between the inclinometer duct axis and the vertical line, so that it can be effective to avoid the occurrence of construction accidents. In this paper, the basic principle of the sloping technology and the importance in the foundation pit engineering are briefly introduced. The existing slanting technology is analyzed and researched, and some suggestions are put forward for the development of the future surveying technology.

**Keywords:** foundation pit engineering; Inclinometer ;Horizontal displacement

---

### I. INTRODUCTION

With the rapid progress of urbanization, underground buildings and underground transportation are rapidly developing, a large number of deep foundation pit engineering have been produced, and the safety of deep foundation pit project is getting more and more attention. The safety of deep foundation pits is not only depends on reasonable design and construction, but also depends on safety monitoring through the whole process of engineering design and construction. In the foundation pit monitoring, Dip test by measuring the dip tube axis and the change of the Angle between the vertical, to get the horizontal displacement in deep foundation pit of soil, so as to ensure the safety of the foundation pit engineering. The active side inclinometer is widely used, which is a kind of device that relies on artificial measurements. It has the defects such as low pitch measurement, long data measuring period and large artificial dependence. There is also a fixed inclinometer, the measurement accuracy is improved, but it is expensive to install multiple surveying probes. In order to overcome the deficiency of the existing inclinometer, a design system of intelligent, miniaturized and refined foundation pit surveying system is proposed.

### II. WORKING PRINCIPLE OF INCLINOMETER

The inclinometer is a commonly used instrument for the whole pit engineering, which can accurately measure the horizontal displacement occurring inside the deep soil of the foundation pit. Inclinometer is usually divided into two types: active and fixed, the active measuring instrument is commonly used in the monitoring of foundation pit. The active inclinometer consists of the probe, the reading instrument, the cable and the measuring tube. Work applications, in the tested soil vertical buried in advance of a total length of not less than special monitoring the depth of dip tube, dip tube with four inside groove, referred to as a guide. Each guide groove is separated by 90 degrees. Install one of the guide grooves in the direction of deformation of the foundation pit, or the direction of displacement of the foundation slope. When the horizontal displacement of the measured soil is embedded in the inclinometer, the inclinometer will be distorted from the vertical direction, and a probe with an inclination sensor is placed in the inclinometer to move back and forth. And the inclination angle of the catheter axis relative to the vertical line is measured. The horizontal displacement value of the soil corresponding to the depth of different soils can be calculated according to the length of the section and the inclination angle. The basic principle of sloping is shown in Fig.1. When the inclinometer is measured, the horizontal displacement of the points on the inclinometer is the accumulated value of the relative displacement of the measuring point to the reference point. According to the mathematical trigonometric formula, we can calculate the horizontal displacement change of the action point of the lower pulley of the probe to the point of action of the upper pulley. The formula is:

$$S_i = L \sin \alpha_i$$

Where: L for distance measurement, usually 0.5m;  $\alpha$  is a certain depth offset angle. The horizontal displacement of the nozzle is the sum of the increments of each segment:

$$S_n = \sum_{i=1}^n L \sin \alpha_i$$

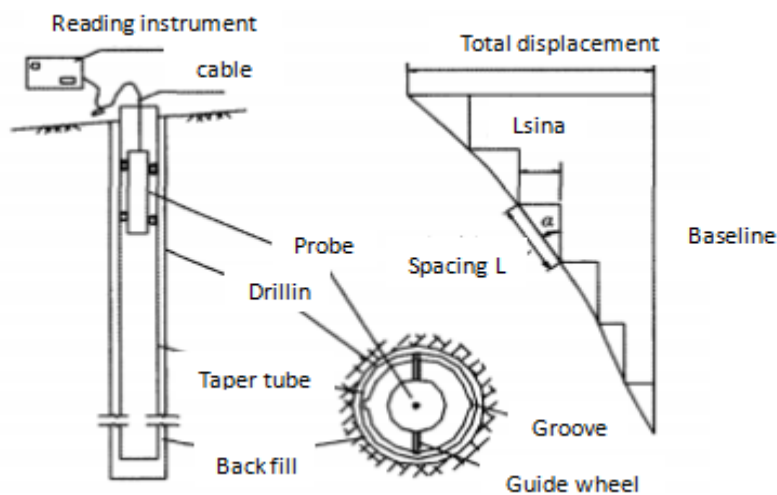

Fig. 1 Basic diagram of inclinometer

### III. THE ROLE OF INCLINOMETER TECHNOLOGY

#### 3.1 The Importance Of Tilting Technology

With the continuous development of urbanization, more and more high-rise buildings have been built up, and high-rise buildings in the construction must be excavated. At the same time, there are more and more underground buildings, such as the city's multi-storey basement, underground malls and large underground garages, especially in recent years, the major cities in order to alleviate traffic pressure, and vigorously promote the construction of urban rail transit, underground buildings and underground traffic. Construction is bound to involve large-scale underground excavation, will inevitably lead to a large number of foundation pit engineering. Therefore, the foundation pit project plays an increasingly important role in the construction of modern city. During the construction of the foundation pit, often accompanied by many security problems. Investigate its reason, the degree of information construction is not high as one of the main causes of frequent accidents. The safety of deep foundation pit construction depends not only on the reasonable design and construction, but also on the safety monitoring throughout the whole process of engineering and construction. In the pit monitoring, the geodesic project, which reflects the horizontal displacement of deep soil, has been one of the most concerned monitoring projects in the industry. The slanting technique can monitor the deep deformation characteristics of the slope of the foundation pit and the shape after the deformation of the pile; calculate the displacement of the soil (pile) at different depths and monitor whether there is any sign and phenomenon of soil instability; The surface of the displacement with the distance from the pit of the law, more scientific and more secure guide construction. Therefore, the measurement technology in the pit engineering safety monitoring plays a decisive role.

#### 3.2 The Effect Of Sloping Technology On The Foundation Pit Environment

The construction of the foundation pit project will affect the surrounding environment, and each foundation pit project surrounding the environment are not the same, have their own characteristics, according to the use of functions and the existence of different forms can be divided into four categories: There are buildings, urban roads, underground pipelines and other facilities.

1. Existing buildings. Most of the foundation pit around the existing use of existing buildings, so in the construction of the pit construction process must ensure that the surrounding buildings have been the normal use of this, which is the primary task of environmental protection around the pit.
2. Urban roads. The roads in the city are in all directions, and most of the foundation pit works in the bustling areas of the city. Once the foundation pit project starts construction, it will definitely affect the convenience of road transportation and bring inconvenience to the whole transportation of the city.
3. Underground pipelines. In the city there are a variety of underground sewage, rainwater pipes, as well as electricity, communications, gas pipeline. And in the pit around the pipeline will certainly be affected. If the underground pit engineering and the implementation of the underground pipeline caused by a large deformation, it will give the lives of urban residents a huge inconvenience.
4. Other facilities. The surrounding wells, bridges and poles and so on will be affected by the construction of foundation pit.

Through the analysis of the surrounding environment of the foundation pit, in order to avoid the normal construction of the foundation pit to the surrounding environment, we must do a good job in protecting the surrounding environment, and the sloping technology in the protection of the surrounding environment plays very Important role. Through the construction personnel of the surveying project, the horizontal displacement of the deep soil inside the foundation pit can be obtained at any time, and the real-time situation inside the foundation pit can be clearly understood. Once the deep soil has the strange situation, the construction personnel can make timely and effective Of the remedial measures, thus avoiding the damage to the surrounding environment of the foundation pit.

**IV. DEVELOPMENT OF INCLINOMETER TECHNOLOGY**

At present, there are many shortcomings of the existing tilt measurement equipment, such as low precision tilt measurement, long measurement cycle, artificial dependence, expensive and so on. For the current shortage, a new pit excavation automatic design system is designed. Designed with the latest high-precision, low-power and small-volume MEMS biaxial acceleration tilt sensor and near-distance wireless ZigBee communication technology, developed an intelligent, miniaturized, fine foundation pit ranging system, the system realizes the function of high precision and remote intelligent monitoring of the base pit 24 hours. The system is divided into automatic lifting control unit, deviation sensing unit, far and near wireless communication unit and power supply unit. The automatic lifting control circuit mainly realizes the accurate lifting and lowering of the contralateral oblique probe. The short-range wireless communication circuit mainly completes the communication between the modules and the transmission of the measurement data. The inclination sensor circuit mainly completes the measurement of the horizontal displacement of the deep soil, Power the entire system.

Figure 2 is the overall software design of the system. When the system is powered up, the initialization settings are made first. Then receive the operating parameters. If no operating parameters are received, the microcontroller is in standby mode until the operating parameters are obtained via serial communication. The parameters of the automatic lift control unit began to control the power stepper motor at a fixed distance down the tilt sensor unit, when reached the set depth, start the internal steering small stepper motor, the MEMS dual axis angle sensor rotation 180 degrees Reverse measurement, used to eliminate the deviation. And then automatically lift the control unit and then control the power stepper motor to a fixed distance pull up the tilt sensor unit. In the whole process of lifting the tilt sensing unit timing sampling angle data and temperature data, and the sampling of the angle data through conversion, get the corresponding displacement data. After all the data through the short-distance wireless transmission to the far-range wireless communication unit, the distance wireless communication unit will receive the data after the package through the remote wireless upload to the Internet. And finally by the Internet access to the computer to receive the data for analysis, display and storage.

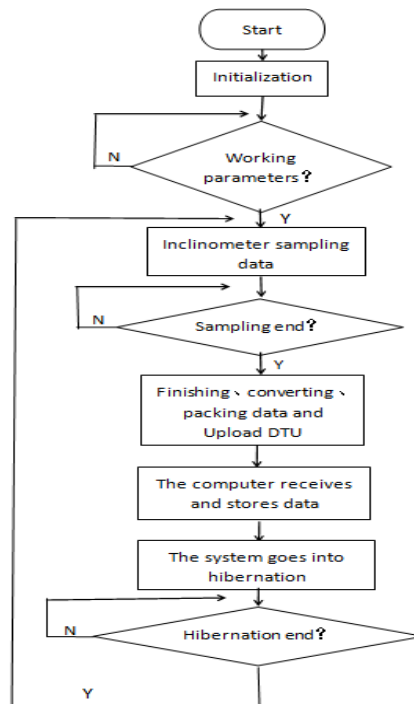

Fig. 2 Software design of the system

## **V. CONCLUSION**

In this paper, the basic principle of the oblique technology is introduced firstly, and then the importance of the slanting technology to the foundation pit engineering and the influence on the surrounding environment of the foundation pit are expounded. For the shortcomings of the existing inclinometer, put forward a new design of the automatic pit surveying system for the foundation pit , and introduce the whole software design of the system in detail.

## **REFERENCES**

- [1]. Wu Wanfeng. Foundation pit monitoring engineering surveying technology [J]. Building materials development direction .2016 (02) .310-311.
- [2]. Zhu Xinzhen. Exploring the surveying technology of foundation pit monitoring project [J]. Journal of Urban Geography .2015 (10) .130.
- [3]. Xie Guijuan. Deep pit excavation technology [J].Journal of Surveying and Mapping Geography, .2012.35 (3) .209-210.
- [4]. Tang Guoqi, Xiao Shengsi. The current situation of drilling and drilling technology and development prospects [J]. Prospecting Engineering. 1999.235-238.
- [5]. Wang Na, Wang Wei stepper motor control system [J] urban construction theory research .2015, (01):